

M22 Air-Cooled Mig Welding Torch

Ratings:	250A CO ₂ , 220A mixed gas M21, 145A pulse. EN60974-7 @ 60% duty cycle. 0.8mm-1.2mm wires
----------	---

A great all-round Industrial torch for high duty 200 Amp solid wires and low duty Pulse Mig Aluminium applications

ARC M LIGHT INDUSTRIAL MIG TORCH PACKAGES

M22 Torches are supplied with a Euro termination as standard and are supplied 'ready to weld' with all wear parts fitted.



Wear Parts

A Nozzles

Part Number	Description	Bore	Wall	Material
•AM22CN	Conical Nozzle Assembly	15mm	1.75mm	Copper
AM22TN	Tapered Nozzle Assembly	12mm	1.75mm	Copper

B Contact Tips

Part Number	Description	Size (mm)	Wire Size (mm-inch)	Material
AM2CT08	Contact Tip	M8*29.5	0.8 - 0.030"	Copper
AM2CT09	Contact Tip	M8*29.5	0.9 - 0.035"	Copper
•AM2CT10	Contact Tip	M8*29.5	1.0 - 0.040"	Copper
AM2CT12	Contact Tip	M8*29.5	1.2 - 0.045"	Copper
AM2CT08A	Contact Tip	M8*29.5	0.8 - 0.030"	Copper
AM2CT10A	Contact Tip	M8*29.5	1.0 - 0.040"	Copper
AM2CT12A	Contact Tip	M8*29.5	1.2 - 0.045"	Copper

C Tip Adaptors

Part Number	Description	Material
•AM22TA	Tip Adaptor	Brass

•Denotes torch package standard wear part set-up

D Liners

Part Number	Description	Wire Size
•AM2524-30	Steel Liner x 3mt	1.0-1.2mm
•AM2524-40	Steel Liner x 4mt	1.0-1.2mm
•AM2524-50	Steel Liner x 5mt	1.0-1.2mm

For alternate liner options please refer to page 22

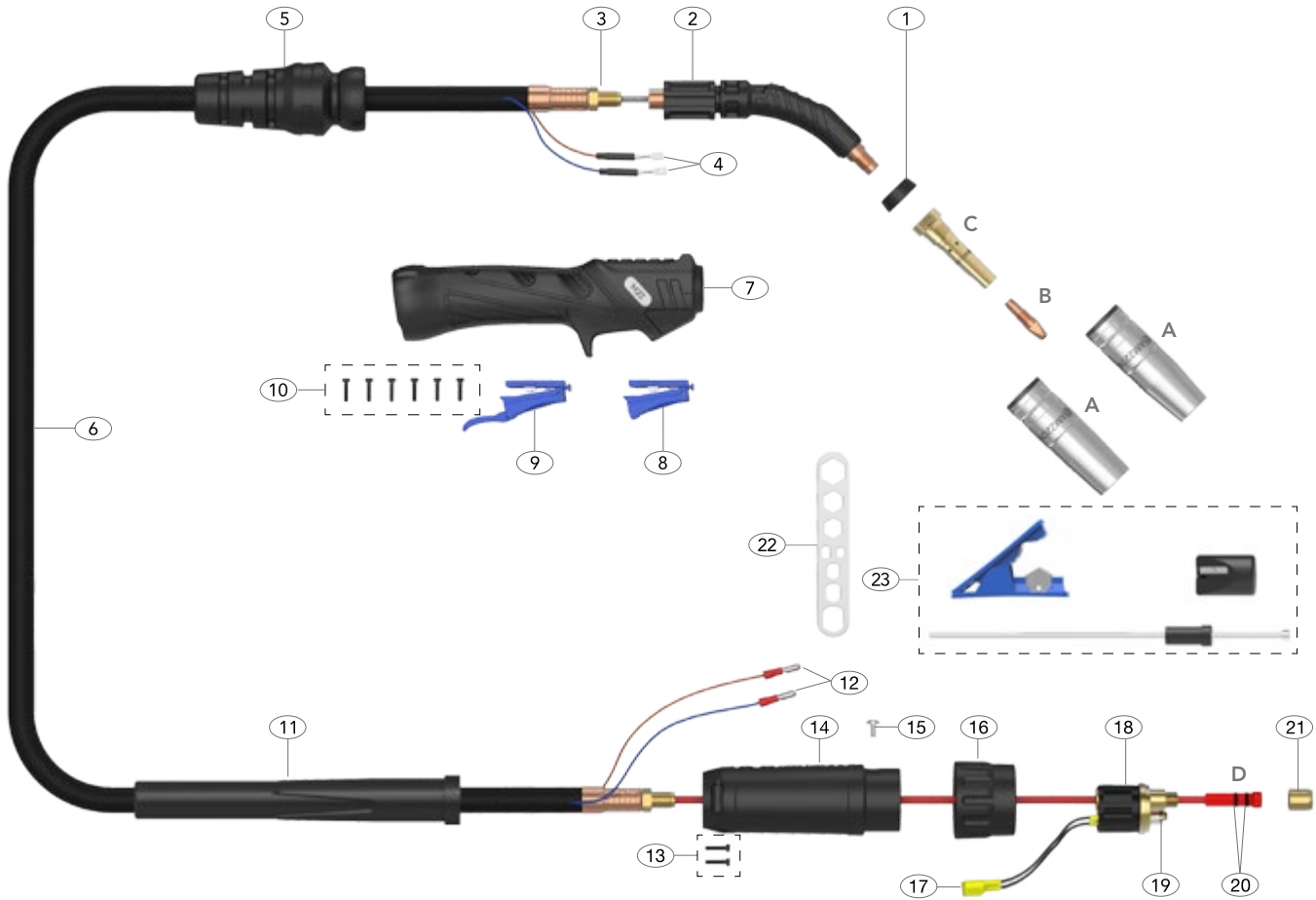

Spare Parts

Part Number	Description
1 AM2AP	Neck Insulator
2 AM22001	Swan Neck Assembly
3 AM1505	Lock Nut
4 AM1521	Cable Terminal
5 AM1514	Handle Cable Support c/w Ball Joint
6 AM2603-30	Ultraflex Cable Assembly x 3mt
AM2603-40	Ultraflex Cable Assembly x 4mt
AM2603-50	Ultraflex Cable Assembly x 5mt
7 AM2514	Handle Kit
8 AM2516	Standard Trigger Assembly
9 AM2516L	Extended Trigger Assembly
10 AMSP1-1	Screw Pack
11 AMPA3541	Cable Support
12 AM1522	Cable Terminal Male
13 AMCSP1-1	Gun Plug Housing Screw Pack
14 AM2578/L	Gun Plug Housing

Part Number	Description
15 AML1541	Gun Plug Screw
16 AMC1519/S	Gun Plug Nut
17 AM1523	Gun Plug Terminal Female
18 AM1528	Hybrid Gun Plug Body c/w Spring Pins
19 AM1524	Gun Plug 'O' Ring
20 AMLOR	Liner 'O' Ring
21 AM1826	Liner Retaining Nut
22 AMWS	Wear Parts Spanner
23 AMCLST-KITS	Combi-Liner Set-up kit - Optional

Welding with Soft Wires

For welding with Aluminum wires use a Combi-liner (page 22). Optimum installation is achieved when using the Combi-liner set-up kit.



Liner Set-up Guide

Always follow the correct liner installation procedure